

# Tantalum Capacitor Benchmark in Portable Audio Applications

**R. Faltus, T. Zedníček**

AVX Czech Republic s.r.o., Dvorakova 328, 563 01 Lanskroun, Czech Republic

**Ian Smith**

Wolfson Microelectronics plc, Westfield Road, Edinburgh, EH11 2QB, UK

**J. Zajaček, J. Šikula**

Department of physics, Brno University of Technology  
Technická 8, 616 00 Brno, Czech Republic

## Abstract

Designers of the latest portable audio/video equipment have a wide choice of capacitor solutions for coupling and line applications. The key design criteria includes clear noise-free filtering (high quality audio), stability with temperature, small size, light weight and reasonable cost versus performance value for consumer electronics. The typical capacitance value demand is from 100 $\mu$ F to 330 $\mu$ F for headphone coupling and 10 $\mu$ F for line applications. More capacitor technologies – tantalum, MLCC, NbO and aluminium can be used to meet the capacitance requirements. Tantalum capacitors are increasingly used today in such applications despite in some cases, especially the 10 $\mu$ F line some cheaper solutions are available.

The paper, that will be prepared together with a leading audio chip manufacturer Wolfson Microelectronics plc, Scotland, will present results of a capacitor benchmark study in small portable audio applications.

## Introduction

There are several technical features required from capacitors used in portable audio devices.

Noiseless audio filtering performance and high fidelity in passing audio signals measured by total harmonic distortion (THD) is required. Stability of electrical parameters over temperature and mainly over time is required to assure an overall sound quality for a long operating time. In most of the cases, portable audio devices emphasize miniaturization and it often constrains designers to choose smaller and lower profile capacitors.

Besides decoupling circuits, where capacitors are largely connected in parallel to power supply lines of signal processing integrated circuits, amplifiers etc., we have a.c.-coupling circuits. This is where the capacitor directly affects quality of the audio signal and that's why its careful selection is important.

The purpose of coupling circuits in audio devices is to separate the unwanted DC voltage from the useful AC signal which we want to let go through to next step of signal processing or to the output device. A coupling circuit can be imagined as a simple C-R differentiator with nominal capacitance C of coupling capacitor and input resistance R of next unit like amplifier, signal processor or output device like headphones or loudspeaker. We are discussing the input resistance R instead of input impedance Z for purposes of simplification and resistance R is equal to modulus of impedance Z. Then low pass frequency is:

*Equation 1:*  $f_L = 1 / (2\pi RC)$

Designers choosing the right value of capacitor for the coupling circuit consider the input impedance of the following circuit versus low pass frequency (see Eq. 1), which is governed by the human ear ability to hear bass tones and it's usually in the range of 20 to 50 Hz. For coupling of circuits to high input impedance like operational amplifiers inputs, low value of coupling capacitor can be sufficient for a perfect bass tone transfer. In such cases like line inputs and outputs capacitors with values from 1  $\mu$ F to 10  $\mu$ F are usually used.

Coupling of output devices like headphones or loudspeakers demands higher capacitance because their nominal impedances are in the range of only 4  $\Omega$  to 32  $\Omega$ . For example headphones with  $Z_N = 32 \Omega$  and considering low pass frequency  $f_L = 50$  Hz require capacitance  $C = 100 \mu$ F.

It demonstrates that the transfer ratio of the coupling circuit is optimal when impedance of capacitor is near to or smaller than impedance of load.

Capacitors made by different technologies can be used for both line and output device coupling circuits. Depending on the technology, they can exhibit different effective serial resistance (ESR) change profiles with frequency. Together with parasitic effects like piezo effect (in the case of MLCC capacitors) high value of ESR at low frequencies can affect sound quality of all devices. In our study we focused on how different coupling capacitor technologies affect overall audio quality, measured by noise background and total harmonic distortion plus noise (THD+N).

### Measuring appliance

For all measurements, evaluation kit WM8960\_6158\_QFN32\_EV1\_REV2 (Ref. 1) with the WM8960 chip were used. The WM8960 (Ref. 2) is low power, high quality stereo codec designed specially for portable digital applications produced by Wolfson Microelectronics plc. Configuration of bypassing internal AD and DA converters was chosen, so only the amplifiers and mixers of WM8960 internal structure were in the signal path (Fig. 1).

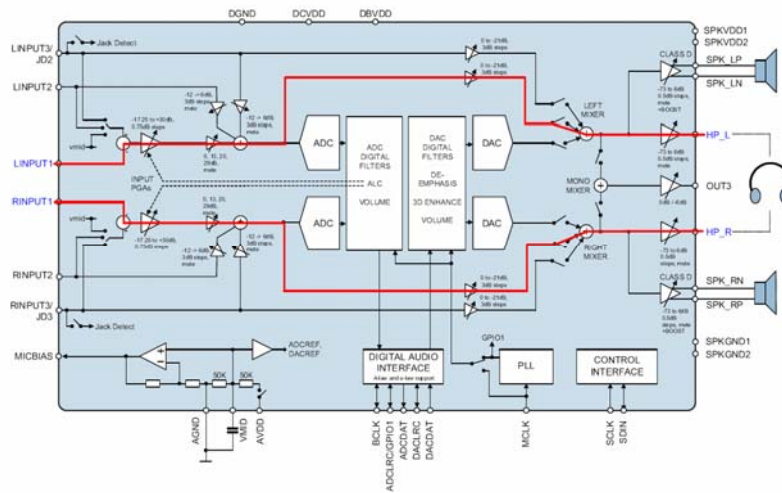

**Figure 1:** WM8960 codec internal configuration

Measurements were realized on the right channel (HPR output) and the parallel left channel was shorted at the input of the developer's kit to minimise the possibility of crosstalk. Used outputs are dedicated for headphones and we took advantage of onboard load of 16 $\Omega$  resistor which was connected at the output of coupling capacitor. The kit

was supplied from external stabilized +5V power supply. The configuration (see Fig. 1) and setting of gain was loaded from PC using configuration software and USB interface.

## Noise background

First we measured the frequency spectrum of the background noise of the evaluation kit configured as described above and then compared the behaviour for different output coupling capacitors. An input coupling capacitor was fixed by use of a standard tantalum capacitor 4.7  $\mu\text{F}$  / 10 V and the input of the measured channel was shorted. The gain of the internal input PGA amplifier of the WM8960 was set to 10.5 dB while other amplifiers in the signal way stayed in default setting 0 dB.

The HPR output was connected by coaxial cable to measuring amplifier 3S Sedlak AM22

(Ref. 3) with configuration: 60 dB amplifier – 0.003 Hz to 30 kHz passing filter – 10 dB amplifier. The output was connected to a sampling card Advantech PCI 1716L (Ref. 4). Data was processed by special FFT with resulting variable frequency step and total amplification of 80.5 dB.

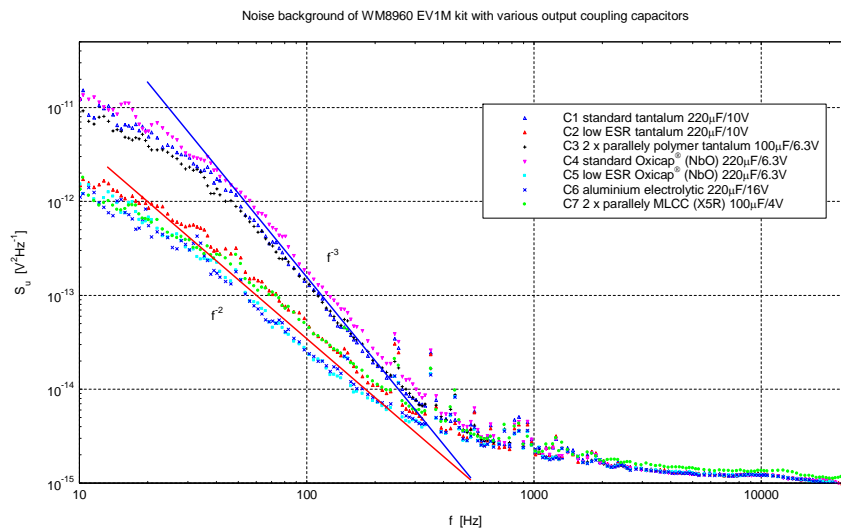

**Figure 2:** Results of background noise measurement

The resulting spectra of background noise is seen in Figure 2, where the output capacitors are as follows (all SMD except C6):

C1 – standard tantalum 220  $\mu\text{F}$  / 10 V; max. ESR = 0.5 $\Omega$  @ 100 kHz

C2 – low ESR tantalum 220  $\mu\text{F}$  / 10 V; max. ESR = 50m $\Omega$  @ 100 kHz

C3 – 2 x parallel polymer tantalum 100  $\mu\text{F}$  / 6.3 V; total max. ESR = 35m $\Omega$  @ 100 kHz, (see Ref. 6)

C4 – standard Oxycap<sup>®</sup> (NbO) 220  $\mu\text{F}$  / 6.3 V; max. ESR = 0.4 $\Omega$  @ 100 kHz, (see Ref. 5)

C5 – low ESR Oxycap<sup>®</sup> (NbO) 220  $\mu\text{F}$  / 6.3 V; max. ESR = 45m $\Omega$  @ 100 kHz

C6 – leaded radial aluminium electrolytic 220  $\mu\text{F}$  / 16 V, (see Ref. 7)

C7 – 2 x parallel MLCC (X5R dielectric) 100  $\mu\text{F}$  / 4 V

The next step was to observe the noise spectrum of a configuration with an output MLCC capacitor which was actuated by an piezoelectric exciter. In practice, a separate board with the MLCC was mechanically fixed to the exciter which was driven by

amplified white noise signal of waveform generator Agilent 33220A, restricted by passband filter to the band 0.003 Hz to 30 kHz.

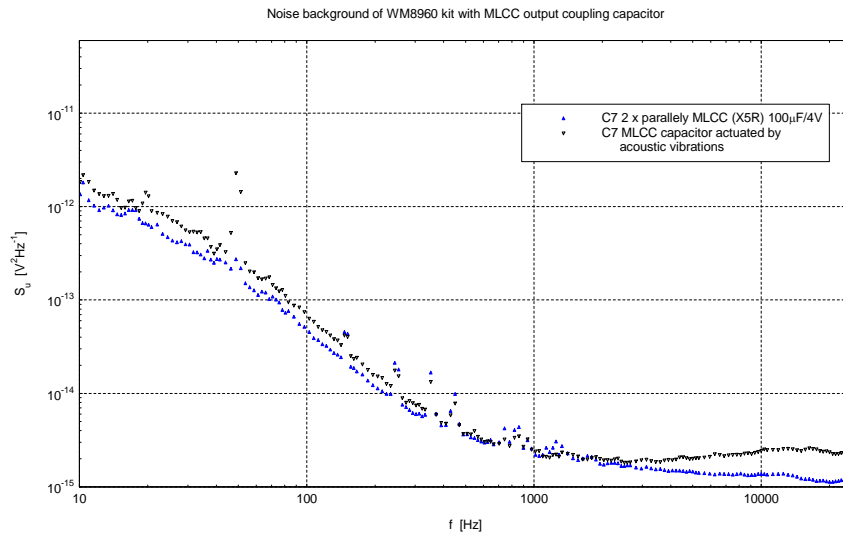

**Figure 3:** Noise spectrum with MLCC actuated by acoustic vibrations

Figure 3 shows the original background noise spectrum with C7, MLCC output capacitor without any vibration source marked as “C7” and the second spectrum is for the same configuration but under acoustic vibrations as described above. The exciter had parameters  $Z = 30 \text{ k}\Omega$  within the active frequency band and it was driven by  $P = 3 \text{ mW}$  in this case.

### **Influence of output coupling capacitor technology over acoustic quality**

Overall acoustic quality of the evaluation kit configuration was measured by THD+N for fixed input coupling capacitor C11 a standard tantalum  $4.7 \mu\text{F}/10 \text{ V}$  and different output coupling capacitors, as the background noise measurement above.

All internal amplifiers of the WM8960 stayed in default gain setting of 0 dB. Harmonic signal from a waveform generator Agilent 33220A within the range of 10 Hz to 20 kHz was connected to the right channel of the evaluation kit input while the input of left channel stayed shorted to minimise crosstalk. The level of the harmonic signal was  $U_{p-p} = 200 \text{ mV}$ . The appropriate board output was loaded by resistor  $R = 16\Omega$  and it was connected to digital THD+N meter NTI Minilyzer ML1.

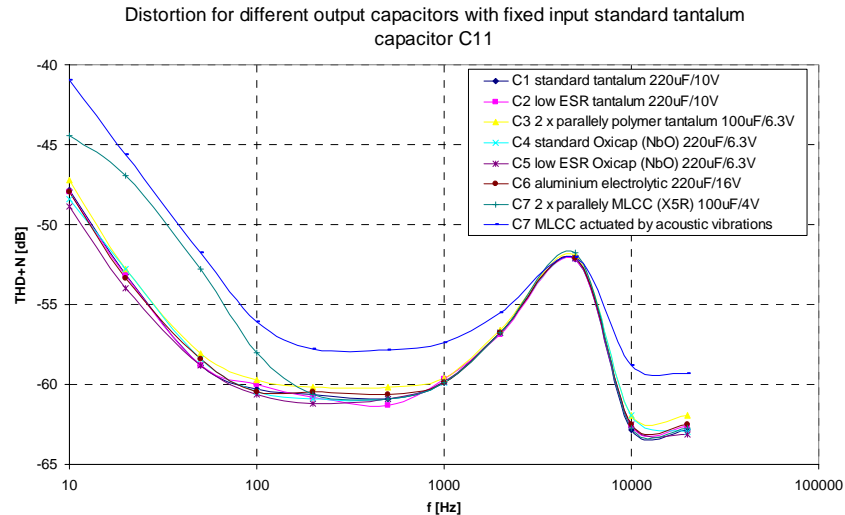

**Figure 4:** Harmonic distortion for different output coupling capacitors

A piezoelectric effect of ceramic capacitors was observed and measured when the piezoelectric exciter was mechanically fixed to the board with output coupling MLCC capacitor C7. The exciter the same like above was driven by amplified white noise from waveform generator Agilent 33220A, restricted by passband filter to the band 0.3 Hz to 30 kHz and its measured input power was  $P = 0.166 \text{ W}$ .

Piezoelectric effect influence over THD+N and comparison of different technologies are seen in the Figure 4.

The drop of all characteristic curves between 5 kHz and 20 kHz (Fig. 4, Fig. 5) is caused by the brickwall filter inside of THD analyser. The filter removes the third harmonic component of the signal and so the measured THD+N is lower.

#### **Influence of input coupling capacitor technology over acoustic quality**

Different output capacitors as well as different input capacitor's influence on THD+N was measured together with piezoelectric effect of MLCC (See the Fig. 5). For all the measurements, a fixed output coupling capacitor was used – C5 low ESR Oxicap (NbO), which exhibited the best results in the previous noise and THD+N measurements.

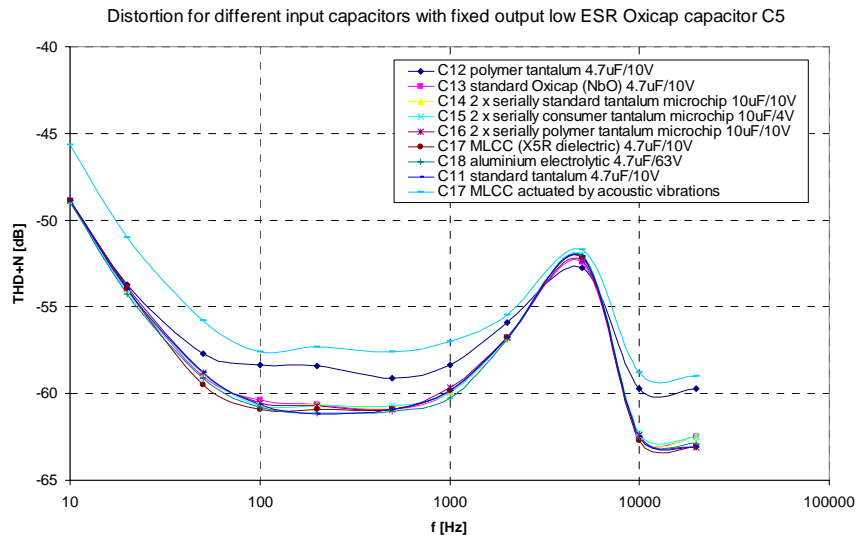

**Figure 5:** Harmonic distortion for different input coupling capacitors

Frequency dependencies of THD+N are for following input coupling capacitors (all SMD except C18):

- C11 – standard tantalum 4.7 µF / 10 V; max. ESR = 9Ω @ 100 kHz
- C12 – polymer tantalum 4.7 µF / 10 V; max. ESR = 0.5Ω @ 100 kHz
- C13 – standard Oxicap® (NbO) 4.7 µF / 10 V; max. ESR = 3.1Ω @ 100 kHz
- C14 – 2x serially standard tantalum microchip 10 µF / 10 V;  
total max. ESR = 15Ω @ 100 KHz
- C15 - 2x serially consumer tantalum microchip 10 µF / 4 V;  
total max. ESR = 15Ω @ 100 KHz
- C16 - 2x serially polymer tantalum microchip 10 µF / 10 V;  
total max. ESR = 4Ω @ 100 KHz
- C17 – MLCC (X5R dielectric) 4.7 µF / 10 V
- C18 – leaded radial aluminium electrolytic 4.7 µF / 63 V

## Summary

*Review table of the output coupling capacitors*

Technology of the capacitor	Background noise transmission	Output capacitor influence over THD+N	Sensitivity to mechanical vibrations	Case size – space requirement
standard tantalum	0	0	++	+
low ESR tantalum	+	+	++	+
polymer tantalum	0	-	++	++
standard Oxicap <sup>®</sup> (NbO)	0	0	++	+
low ESR Oxicap <sup>®</sup> (NbO)	++	++	++	+
aluminium electrolytic	++	0	++	-
MLCC	0	-	-	0

*Explanation:* ++ very good, + good, 0 neutral, - not good  
 THD+N total harmonic distortion + noise

Review table of the input coupling capacitors

Technology of the capacitor	Input capacitor influence over THD+N	Sensitivity to mechanical vibrations	Case size – space requirement
standard tantalum	++	++	+
polymer tantalum	-	++	+
standard Oxicap <sup>®</sup> (NbO)	0	++	0
standard microchip tantalum	++	++	++
consumer microchip tantalum	++	++	++
polymer microchip tantalum	0	++	++
aluminium electrolytic	++	++	-
MLCC	+	-	0

*Explanation:* ++ very good, + good, 0 neutral, - not good  
THD+N total harmonic distortion + noise

- Low ESR capacitors pass less noise to the output than standard ESR parts; the exception is polymer tantalum capacitors which exhibit similar behaviour like standard parts.
- Low ESR output capacitors exhibited lower overall THD+N, specially low ESR Oxicap<sup>®</sup> (NbO).
- In the position of input coupling capacitor, standard polymer exhibited higher THD+N; all other technologies were comparable.
- MLCC is very sensitive to mechanical vibration in both positions of input and output capacitor and its piezo effect has negative influence over THD+N and noise background. The MLCC output capacitor performance was inferior to the tantalum and Oxicap<sup>®</sup> capacitors.
- Microchip tantalum standard and consumer capacitors exhibited good performance and they offer also very good volumetric efficiency.
- Aluminium leaded capacitors showed a good performance in both input and output circuits but they have the highest space requirements, mostly their height can be limiting for some applications.
- There is a certain drop of THD+N characteristic curves between 5 kHz and 20 kHz (Fig. 4, Fig. 5). This is caused by the brickwall filter inside of THD analyser, which is removing third harmonic component of the measured signal.

### Conclusions and Recommendations

- Special attention should be paid to selection of output capacitor technology due to the sound quality of audio device is more sensitive to output coupling capacitor than input capacitor.
- The best audio performance can be achieved by using low ESR tantalum and Oxicap<sup>®</sup> technology capacitors, except tantalum polymer technology that has worse result especially at lower frequencies.

- Low ESR OxiCap<sup>®</sup> technology was the best in performance. Low ESR tantalum capacitors were rated the second best, closely after low ESR OxiCap<sup>®</sup>. The selection between tantalum and OxiCap<sup>®</sup> depends on application requirements like mounting space and operating voltage.
- MLCC can not be recommended for output coupling capacitor. Special attention should be paid to the risk of piezo effect that can be induced for example by vibrations of the PCB as verified during this test.
- Aluminium capacitors performed well in the tests, however a special care should be paid to their limited reliability, capacitance drop with time, volumetric efficiency and lead-free process compliance. This is beyond scope of this paper. For Reference see 7.

## References

- 1] Manual and software of Wolfson WM8960\_6158\_QFN32\_EV1\_REV2 evaluation kit, <http://www.wolfsonmicro.com/products/WM8960EV1>
- 2] Datasheet and product flyer of Wolfson WM8960 digital audio codec chip, <http://www.wolfsonmicro.com/products/WM8960/>
- 3] Producer of measuring devices, [http://www.3ssedlak.cz/en/index\\_en.html](http://www.3ssedlak.cz/en/index_en.html)
- 4] Datasheet of Advantech PCI 1716L measuring PC card [http://taiwan.advantech.com.tw/unzipfunc/Unzip/1-M2QHV/PCI-1716L\\_DS.pdf](http://taiwan.advantech.com.tw/unzipfunc/Unzip/1-M2QHV/PCI-1716L_DS.pdf)
- 5] T.Zednicek, B.Vrana et col., "Tantalum and Niobium Technology Roadmap", <http://www.avx.com/docs/techinfo/tantniob.pdf>
- 6] T.Zednicek, „Tantalum Polymer and Niobium Oxide capacitors“, <http://www.avx.com/docs/techinfo/newtant.pdf>
- 7] T.Zednicek, „AVX OxiCap<sup>™</sup> Outperforms Aluminum Electrolytic Capacitors in Consumer Applications“, [http://www.avx.com/docs/techinfo/oxi\\_vs\\_al.pdf](http://www.avx.com/docs/techinfo/oxi_vs_al.pdf)
- 8] Application note „A.C. Coupling Capacitor Selection” <http://www.wolfsonmicro.com/uploads/documents/en/WAN0176.pdf>

